



Premier Truck Body Ltd.
 25355 56th Ave, Aldergrove, BC V4W 1G5
 Tel: (604) 607-1113 Fax: (604) 856-1265
 www.premiertruckbody.com
 info@premiertruckbody.com



DH-LM SERIES - CANTILEVER LIFT GATE



ADJUSTABLE LEVEL RIDE with AUTO TILT AT GROUND LEVEL

CAPACITY: 1000-2500KG (2200-5500LBS)	PLATFORM (L X W): 2000 x 2400 mm (79" x 95")
PLATFORM MATERIAL: STEEL or ALU	FLOOR TO BOTTOM OF CHASSIS (C): 720mm (28") call
2 YEAR LIMITED WARRANTY	FLOOR MAX (K): 1305mm (51") call

THE DH-LM series lifts are extremely versatile full size lifts suitable for commercial trucks above 7.5T GVW, trailers and semi-trailers. This powerful 4 cylinder lift is available with reinforced steel platforms or light-weight aluminum platforms up to 2250mm. Longer platforms are available in combination with lift type DH-LM.30 Special applications are available with half width platforms, lifts with short overhang, or for tipper vehicles. Please call to inquire for special applications, the possibilities are endless.

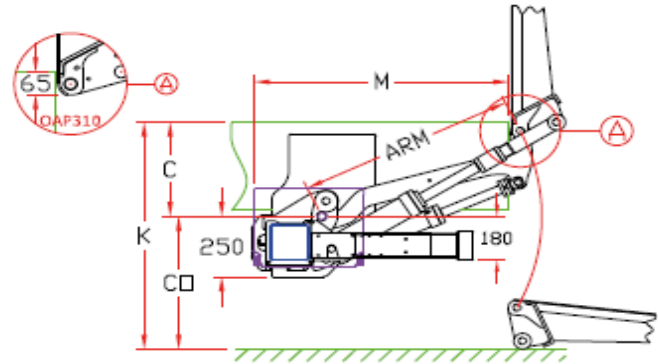

DH-LM .20 specifications shown

NET WEIGHT +/- : 264 - 575KG (582-1267 LBS)

STANDARD FEATURES:	AVAILABLE OPTIONS:	
NO WELDING, BOLT ON INSTALLATION SYSTEM	OAT003	SEAL KIT 3 SIDES
JOYSTICK CONTROL WITH SHUTOFF	OAT001	SEAL KIT 4 SIDES
2 BUTTON REMOTE SPIRAL	E0122	FLAT MOUNT CONTROL IN CARGO AREA
4 CYLINDER, ADJUSTABLE, LEVEL RIDE W/ AUTO TILT	OAM024	STEP BUMPER MOUNT REQUIRES OAF100.ST
GALVANIZED FRAME	OAF100.ST	STEEL BUMPER, 3PC
ALUMINUM PLATFORM WITH BUILT IN CART STOPS		

Available DHLM.10 for 1000KG, DHLM.20 for 2000KG, DHLM.30 for 2500KG - SPECIFICATIONS DIFFER / APPLICATION

To see this lift gate in action go to www.premiertruckbody.com and click on the link for this model.

For more details or product pricing please call us today!

Let us lift your business to new levels!